

***What is an ESB
and
Which do you need?***

**Alan Powell,
IBM Hursley ESB Development**

04/03/2008

Agenda

- ESB Concepts and Architecture
- Federated ESB
- ESB Product Selection Criteria
- IBM ESB Products and Beyond
- Decision Guide
- ESB Example Architectures

ESB Concepts

ESB – an Architectural Pattern

*We describe the enterprise service bus first and foremost as **an architectural pattern**. In fact, it is possible to construct service buses from a variety of different underlying integration technologies....*

*The architecture pattern remains valid and is a guiding principle to enable the integration and **federation** of multiple service bus instantiations.*

Rob High, SOA Foundation Chief Architect, in
SOA Foundation Architecture Whitepaper

Core Principles of the ESB Architectural Pattern

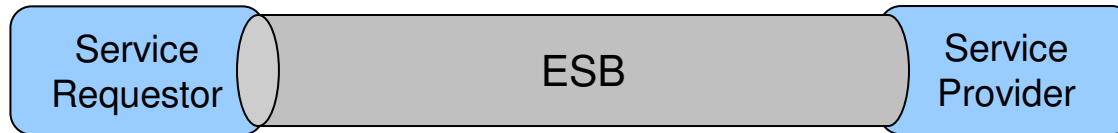

- ESB inter-connects requestor and provider
 - Interactions are *decoupled*
 - Supports key SOA principle – *separation of concerns*
- ESB provides **Service Virtualization** of
 - *Identity* via routing
 - *Protocol* via conversion
 - *Interface* via transformation
- ESB also enables **Aspect Oriented Connectivity**
 - Security
 - Management
 - Logging
 - Auditing
 - ...

An ESB-centric view of the SOA Foundation Logical Model

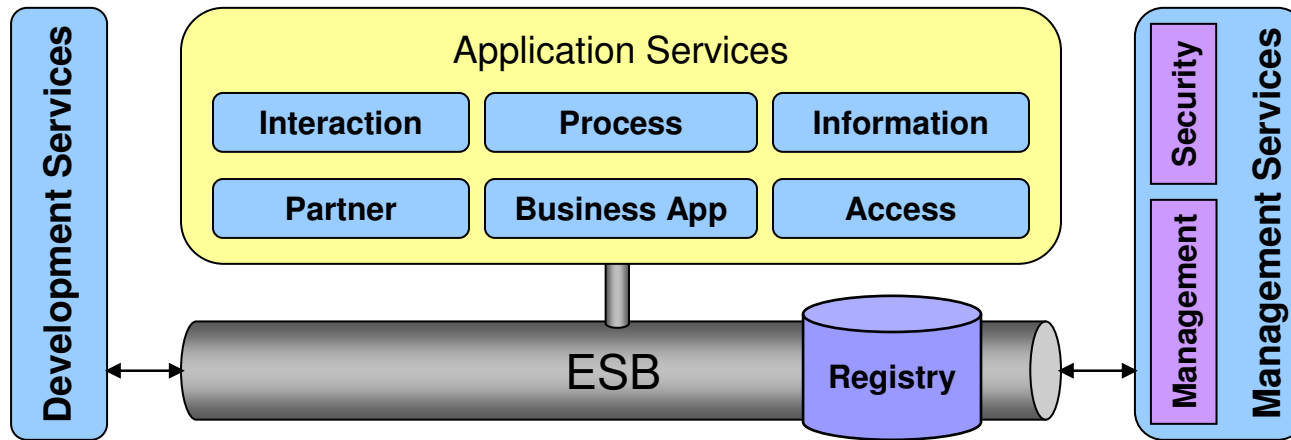

- Outside ESB
 - Business Logic (Application Services)
 - ESB contains connectivity logic
 - Criteria: semantics versus syntax
- Loosely coupled to ESB
 - Security and Management
 - Policy Decision Point outside the ESB
 - ESB can be Policy Enforcement Point
- Tightly coupled to ESB
 - Service Registry
 - Registry a Policy Decision Point for ESB
 - ESB a Policy Enforcement Point for Registry
 - But, Registry has a broader scope in SOA
- Tooling required for ESB
 - Development
 - Administration
 - Configure ESB via Service Registry

Described in <http://www-128.ibm.com/developerworks/architecture/library/ar-esbpat1/>

Expanded view of the ESB

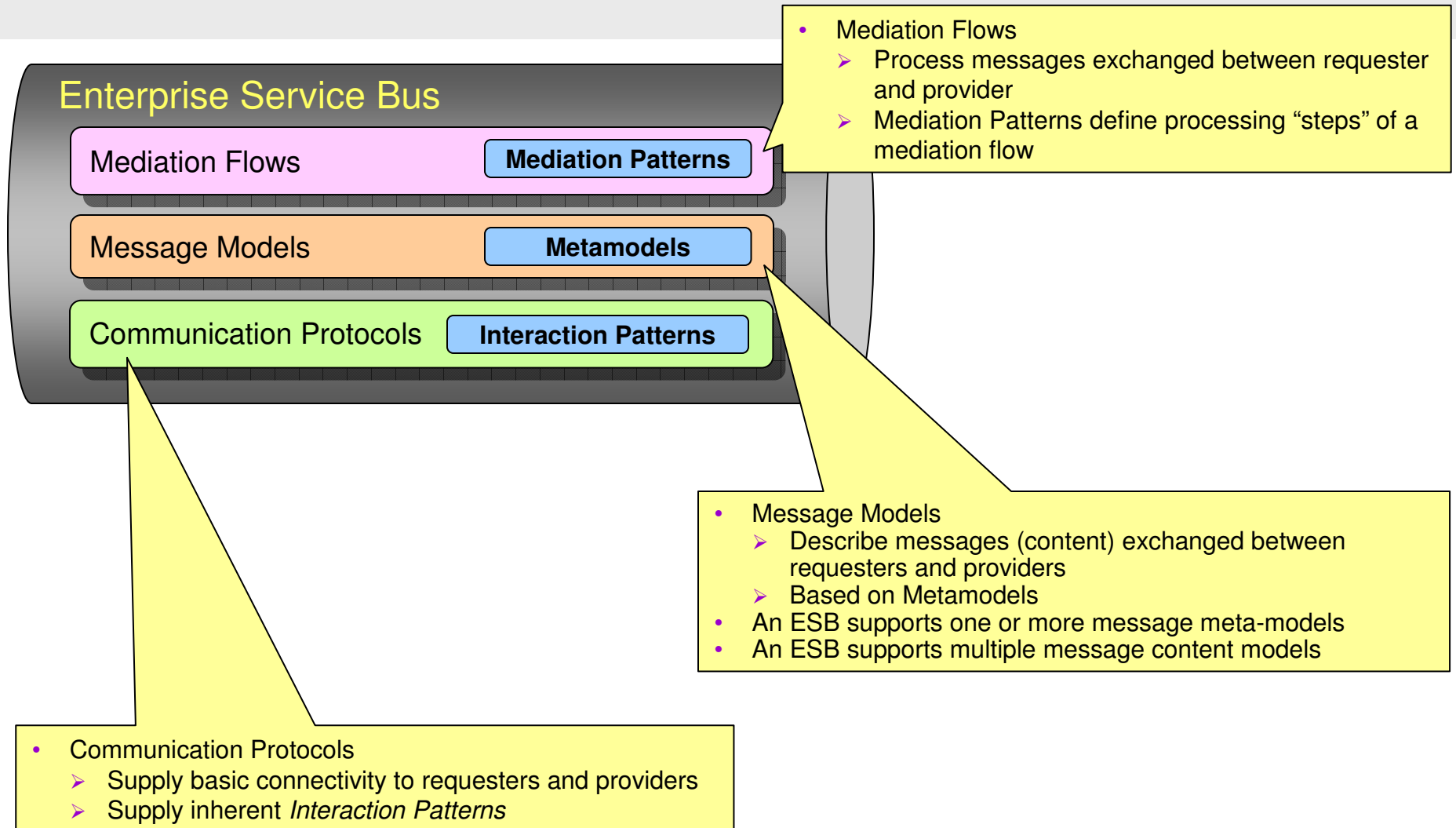

ESB Mediation Flows and Mediation Patterns

- Mediation enables **Service Virtualization** of
 - *Identity* via routing
 - Using basic mediation patterns (context, content, contract)
 - Using composed mediation patterns (retry, failover, Distribution/aggregation, ...)
 - Dynamic, driven by metadata in registry
 - Impact aspects of QoS (e.g., SLA, failover)
 - *Protocol* via conversion
 - Protocol conversion inherent with support for more than one transport protocol
 - Impact aspects of QoS (e.g., reliable delivery, transactions)
 - *Interface* via transformation
 - Using specific mediation patterns
 - Using adapters
 - Impact aspects of QoS (e.g., performance)
 - NOTE: other forms of mediation should be agnostic to interface (weakly-typed processing)
- Mediation enables **Aspect Oriented Connectivity**
 - Security & Management
 - Logging
 - Auditing
 - ...
- Provided by a mediation framework
 - Offering pre-built mediation pattern (primitives) support
 - Enabling mediation pattern composition

Federated ESB

ESB Topology Pattern Examples

ESB

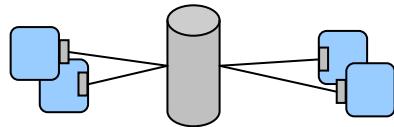

Rich service virtualization and aspect oriented connectivity

ESB Gateway

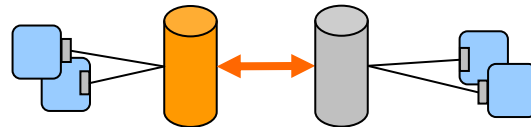

Controlled and secure service interaction between internal or external domain boundaries

Federated

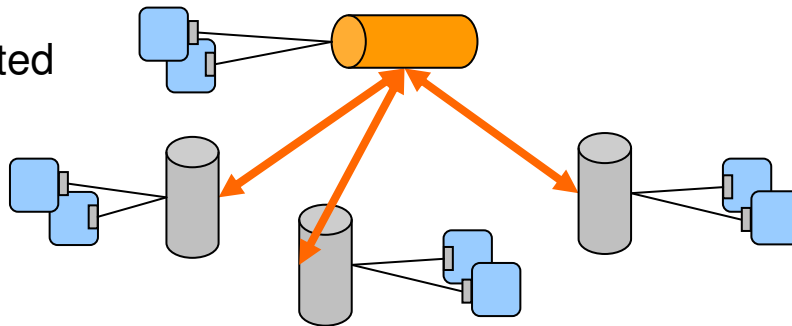

Multiple namespaces, administration domains; namespace mapping in Federated ESB facilitates service interaction with multiple implementations; subset of services applicable throughout the enterprise

Why Federated?

- Different “Domains” in Enterprise
 - Business and Funding Models are Distributed or Federated
 - Distributed geographical locations
 - Distributed Governance
 - Differing ESB requirements best met by different products
 - Acquisitions have existing ESB infrastructure in place
 - Decoupling to allow asynchronous development and deployment
- Best Practice – Architecture aligned to business model
- Best Practice – Isolate critical environments
- Yet ... enable Enterprise-level service reuse across domains

Managing Multiple ESBs – Federated ESB Topology Patterns

A single enterprise-wide ESB is rarely attainable – most businesses will have multiple ESBs across business units

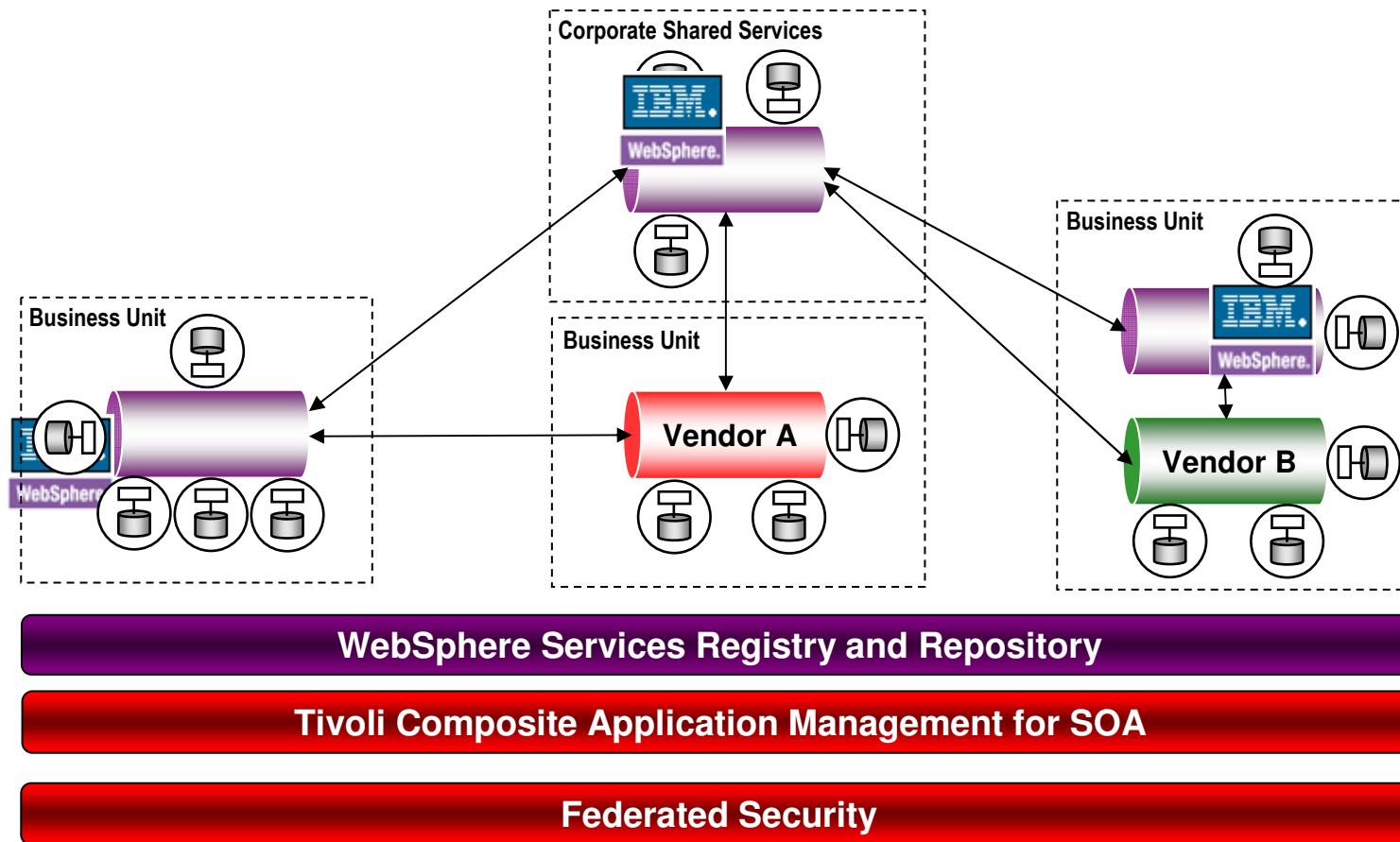

Federated ESB Defined

- The Enterprise Service Bus consists of all the domain service buses, and the backbone bus if needed
- Service messages flow across more than one bus
- Majority of service requests to providers are within a domain and are mediated by a single domain service bus
- Some shared services may be **provided** by a domain for use by other domains
- Some consumers in one domain may **request** services provided by another domain
- All service requests between domains maybe routed by a 'backbone bus'
 - Common aspects can be applied
- Enterprise services may be available directly on the backbone bus
- Also federated
 - Service registry
 - Security
 - management

Client 2 Example of Federated ESB

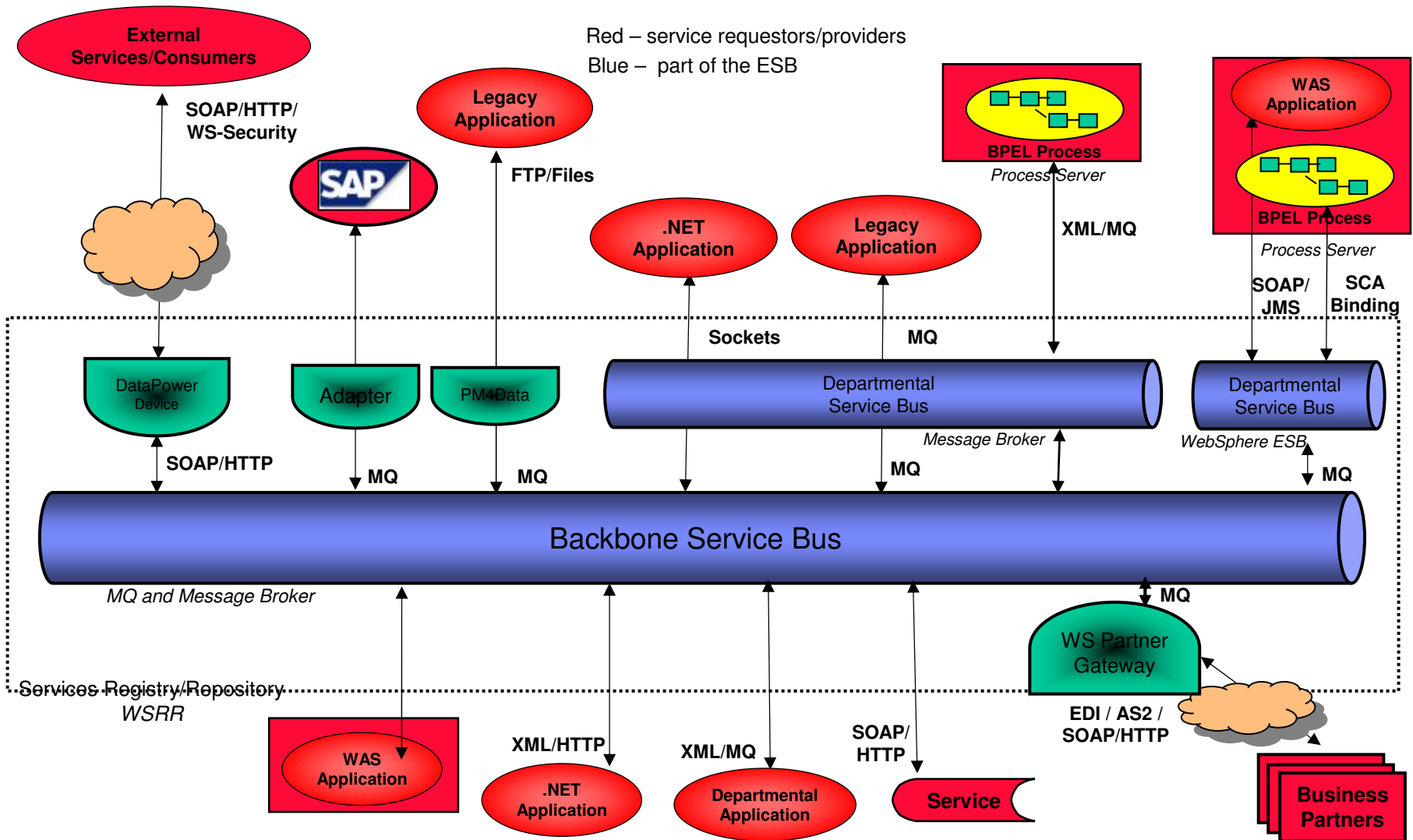

Product Selection Criteria

Key Criteria for ESB selection

- This is a work in progress
 - It does not address all details (and therein lives the devil)
 - Product selection remains an art rather than a science

- **IMPORTANT**
 - Sometimes, even often, the answer is not one product, but multiple products and technologies

Key Criteria for ESB selection

- Communication Protocols & Interaction Patterns
 - Critical (e.g., MQ, SOAP/HTTP, pub/sub)
 - Accommodated
 - “Associated” standards (e.g., WS-Security, headers)
 - APIs (e.g., JMS)
 - Adapters (e.g. SAP)
- Message Models & Meta-models
 - Critical (e.g., specific XML schema)
 - Accommodated
 - “Associated” standards (e.g., SOAP headers, attachments)
 - “Optimizing capabilities” (e.g., Weak-typing, validation)
 - Adapters (e.g. SAP IDOC)

Key Criteria for ESB selection (cont.)

- Mediation Flows and Mediation Patterns
 - Service virtualization
 - Conversion
 - ❖ Protocol
 - » Dependent on suite of on/off-ramps
 - » Explicit correlation may be needed
 - ❖ Interaction pattern
 - » Request/response, pub/sub, ...
 - » Some patterns can require custom work (e.g., scatter/gather)
 - Routing
 - ❖ Simple
 - ❖ Some patterns may require custom work (e.g., retry failover)
 - Service virtualization
 - Transformation
 - ❖ Engine based on message metamodel(s)
 - ❖ Enrichment
 - ❖ Filtering

Key Criteria for ESB selection (cont.)

- Mediation Flows and Mediation Patterns (cont.)
 - Aspect oriented connectivity
 - Management integration
 - Security integration
 - Logging, monitoring, auditing integration
 - ❖ Database, CEI, file, ...
 - Breadth of pre-built mediation primitives
 - Custom mediation capability and Programming model
 - Weak-typing
 - Support for pre-built mediation flows (templates)
 - Metadata driven
 - Ideally all mediation flows are metadata driven
 - Registry access

Key Criteria for ESB selection (cont.)

- Qualities of service
 - Heterogeneous transaction coordination
 - Reliable/assured delivery
 - Performance
 - Message size
 - Throughput
 - Scalability
 - Reliability
 - Availability

Key Criteria for ESB selection (cont.)

- Non-functional
 - Affinity to SOA environment (e.g., WebSphere Process Server)
 - Affinity to IT environment (e.g. J2EE application server)
 - Ease of integration with
 - Monitoring and management infrastructure
 - Security infrastructure
 - Development tooling capabilities and affinity to current tools
 - Configuration and administration tooling capabilities
 - Existing and required skill set (e.g., J2EE skills)
 - Product maturity and comfort level with leading edge products
 - Price and total cost of ownership

IBM ESB Products

ESB offerings from IBM WebSphere

WebSphere delivers the most complete ESB solution



WebSphere ESB
*Built on WebSphere
Application Server for an
integrated SOA platform*



**WebSphere
Message Broker**
*Universal connectivity
and transformation in
heterogeneous
IT environments*

**ESB
Offerings from
IBM WebSphere**



**WebSphere DataPower
Integration Appliance**
*Purpose-built hardware ESB
for simplified deployment and
hardened security*

ESB offerings from IBM WebSphere

Each delivers a common set of ESB capabilities

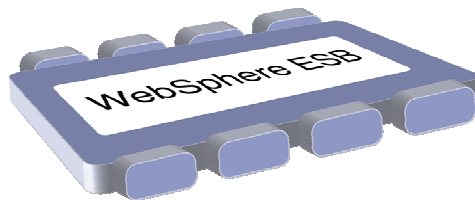

- Mediations to enable common patterns
- Transformation of common data formats
- Connectivity via common protocols

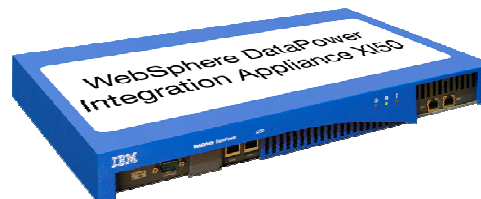

- Leading web services standards
- First class interoperability between ESB products
- Mission-critical qualities of service

Features which are Common Across all ESBs ...

- Communication Protocols & Interaction Patterns
 - HTTP(S), MQ, synchronous, one-way, pub/sub, JMS, SOAP
- Message Models & Meta-models
 - XML, text, binary, XSD
- Mediation Flows and Mediation Patterns
 - XSLT transformation, logging, DB enrichment, protocol conversion
 - Filtering, basic routing, content-based routing, exception handling
- Qualities of Service
 - Basic failover, scalability and reliability
- Additional Features
 - Graphical tool environment
 - Endpoint lookup in a Registry (with limitations)
 - Ability to be monitored
 - Basic runtime configuration change capability
 - Integration with other IBM WebSphere and Tivoli products

WebSphere ESB

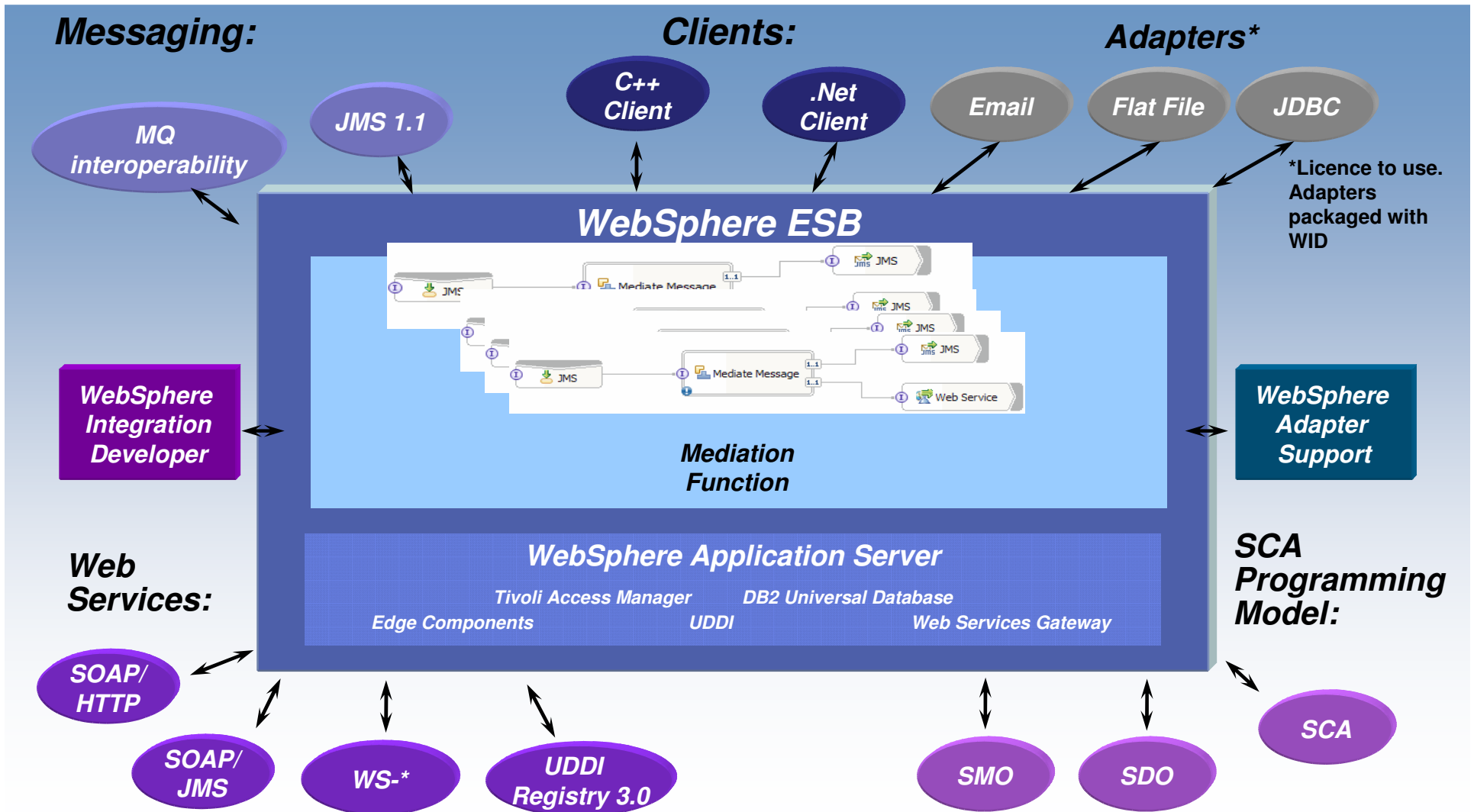

WebSphere Enterprise Service Bus V6.1

- Supports a broader set of mediation patterns quickly and with reduced development effort
 - New message splitting and aggregation patterns
 - New service retry capability
 - Updated Business Object Mapper and relationship support
- Integrates a broader range of services with expanded connectivity
 - New WebSphere TX integration
 - New WS-Notification support
 - New generic HTTP support
 - Enhanced 3rd party JMS support
- Enables streamlined operational infrastructure with platform currency
 - Updated WAS 6.1 based runtime
 - New and expanded OS platforms, including 64-bit exploitation and i5/OS support
- Improves consumability and usability across the solution lifecycle
 - Easier server installation and configuration
 - Expanded XML and WSDL support

WebSphere Message Broker

ESB built for universal connectivity and transformation in heterogeneous IT environments

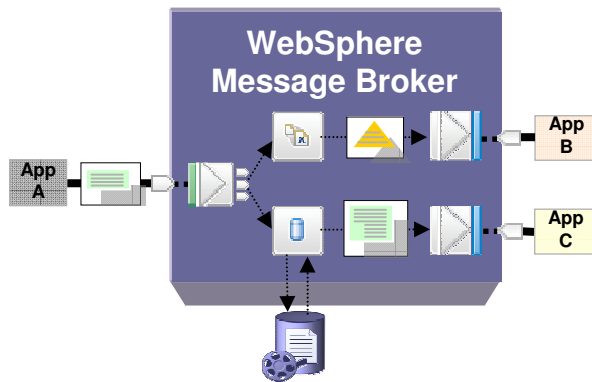

WebSphere MQ, JMS, HTTP,
Web services standards, Java,
C++, ESQL, COBOL,
Industry formats

- Exploits the industry-leading WebSphere MQ messaging infrastructure
- Supports a broad range of protocols, including MQ, JMS, HTTP(S), Web Services, File, and user-defined
- Supports a wide range of data formats, including XML, binary (COBOL, C), positional/delimited, and industry formats (EDI, SWIFT)
- Provides clients multiple ways to customize mediation, including C / C++, ESQL, and Java
- Optimized for high-volume processing and complex mediation capabilities
- Easy to use, graphical tooling and a simple programming model for connectivity and mediation, including a robust set of pre-built mediation function
- WebSphere Adapters for enterprise applications (SAP, Oracle)
- Offers z/OS clients platform-specific benefits (CICS, VSAM)

- Delivers universal connectivity and transformation
- Provides a flexible solution to address a wide range of requirements
- Optimized to accommodate any IT environment
- Offers unique quality of service and connectivity on z/OS

WebSphere Message Broker V6.1

- Enhances consumability and productivity
 - Reduce time to get started
 - Simplifies development tasks and debug
- Enhances SOA support
 - Supporting Web Services natively with WS-security and WS-Addressing
 - Integration with DataPower SOA appliance
 - Out of the box integration with WSRR
- Extends connectivity
 - Built in nodes for EIS access: SAP, Siebel and PeopleSoft
- Native support for very large file processing, including FTP
 - New SMTP node
 - Improved WTX integration
- Simplifies administration and systems management
 - Enterprise wide identity, authentication and authorization with Tivoli Federated Identity Manager and LDAP
 - Common Eclipse based tool for MQ and Message Broker
 - Manageability improvements
- Extends platform support and performance
 - 64 bit Linux, JDBC XA support, Java5
 - Ultra High Performance XML parser including schema validation
 - Compact memory footprint, real time graphical performance analytics
 - Significant performance improvement on ALL platforms

WebSphere Data Power Integration Appliance X150

Purpose-built hardware ESB for simplified deployment and hardened security

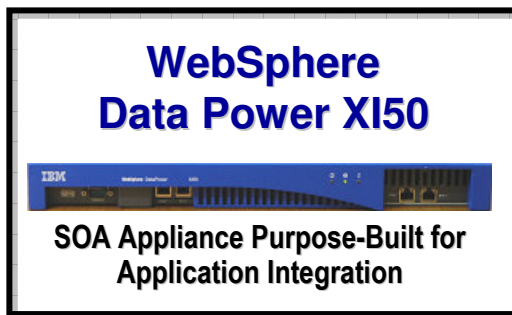

Protocol bridging, hardened security, superior performance

- DataGlue “Any-to-Any” Transformation Engine
- Content-based Message Routing - Message Enrichment
- Protocol Bridging (HTTP, MQ, JMS, FTP, etc) - Request-response and sync-async matching
- Direct to Database - communicate directly with remote database instances
- XML/SOAP Firewall - Filter on any content, metadata or network variables
- Data Validation - Approve incoming/outgoing XML and SOAP at wirespeed
- Field Level Security- WS-Security, encrypt & sign individual fields, non-repudiation
- XML Web Services Access Control/AAA - SAML, LDAP, RADIUS, etc.
- MultiStep - Sophisticated multi-stage pipeline
- Web Services Management – Centralized Service Level Management, Service Virtualization, Policy Management
- Easy Configuration & Management - WebGUI, CLI, IDE and Eclipse Configuration to address broad organizational needs (Architects, Developers, Network Operations, Security)

- Redefines the boundaries of middleware with specialized hardware
- Many functions integrated into a single device
- Simplified deployment and ongoing management

WebSphere DataPower Integration Appliance XI50 V3.6.1

- **Expanded integration and connectivity**

- Enhanced MQ support
- Full support for WS-ReliableMessaging (WS-RX)
- Additional support for VLAN and NFSv4
- Enhanced support for WSRR and UDDI v3 registries
- Full support for SOAP 1.2, WS-Security 1.1 updates
- Integration with DB2 V9 pureXML
- Expanded WS-* support

- **Enhanced governance capabilities**

- Dynamic WebServices policy framework (WS-Policy and WS-Security Policy)
- WS-I Basic Profile and Basic Security Profile support

- **Breakthrough enhancements for ease of use**

- Streamlined Multi-step Transaction Processing
- Expanded Quality of Service (QoS) support

WebSphere DataPower

Specialized hardware can simplify, secure, and accelerate your ESB implementation

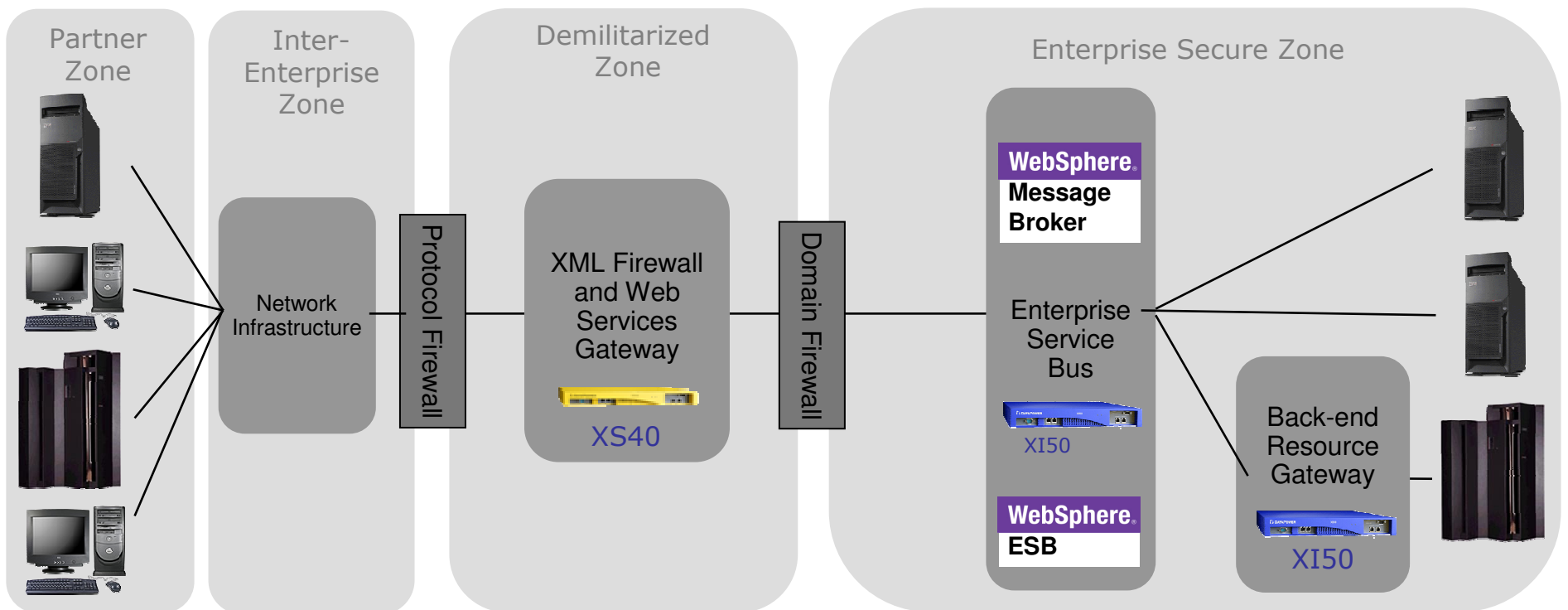

ESB offerings from IBM WebSphere

An ESB without limits to enable complete SOA and BPM solutions

Service Registry



WebSphere Services Registry and Repository

Service Orchestration and BPM

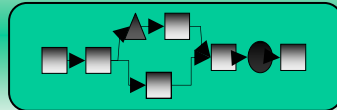

WebSphere Process Server

Service Monitoring

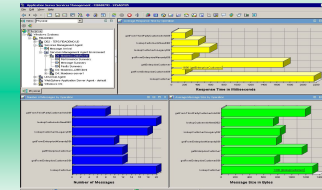

Tivoli CAM for SOA

Universal Transformation

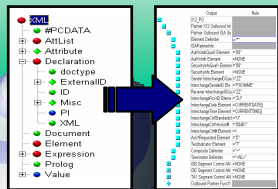

WebSphere Extender

ESB offerings from IBM WebSphere

Service Enablement

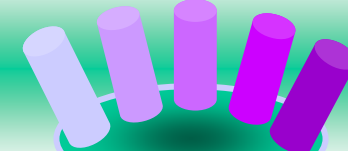

WebSphere Adapters

Enterprise Messaging Backbone



WebSphere MQ

SOA Security Appliance

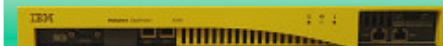

WebSphere Data Power XML Security Gateway XS40

Simplified Decision Guide

– When to use WebSphere ESB?

- You use WebSphere Application Server
 - Your team has skills with WAS Administration and Java coding
- You are now or planning on developing business processes using WebSphere Process Server
 - Common tooling, programming model, and runtime
- You are integrating with ISV business applications hosted on WAS or 3rd party solutions which extend and support WAS
- You are focused on standards based interactions using XML, SOAP, and WS*
- You want to mediate between Web services and existing systems using JMS and WebSphere JCA Adapters
- Reliability and extensive transactional support are key requirements
- You want to minimize your server investment by co-hosting WebSphere services and ESB in one application server

Simplified Decision Guide

– When to use WMB v6?

- You are currently using WebSphere Message Broker
 - Migrate to V6; implement ESB Patterns
 - Leverage existing WMB skills
- You have extensive heterogeneous infrastructures, including both standard and non-standards-based applications, protocols, and data formats
 - You have extensive MQ skills and infrastructure
 - You are using Industry formats such as SWIFT, EDI, HL7
- You are implementing more complex messaging and integration patterns
 - Examples include event processing, message splitting, aggregation
- You need extensive pre-built mediation support
- You have complex transformation needs
- Reliability and extensive transactional support are key requirements
- To achieve high performance with horizontal and vertical scaling

Simplified Decision Guide

– When to use DataPower XI50?

- Ease of use is a pre-dominant consideration
 - Simple experience of drop-in installation and admin-based configuration with no or minimal development required
- You are transforming between XML-and-XML or XML-and-any other format
- You are using XML-based or WS-Security extensively
- Your interaction patterns are relatively simple
- You require use of advanced Web services standards
- Your mediation requirements are met by the existing DP mediations and minimal extensibility is needed
- You need to minimize message latency when adding an ESB layer
- You are doing extensive XML processing combined with high performance requirements
- Your ESB must be in production very quickly

Note: When using an ESB Gateway pattern, use DataPower XS40

- All XML interaction with 3rd parties should go through XS40 for XML threat protection

ESB Example Architectures

Internal Connectivity

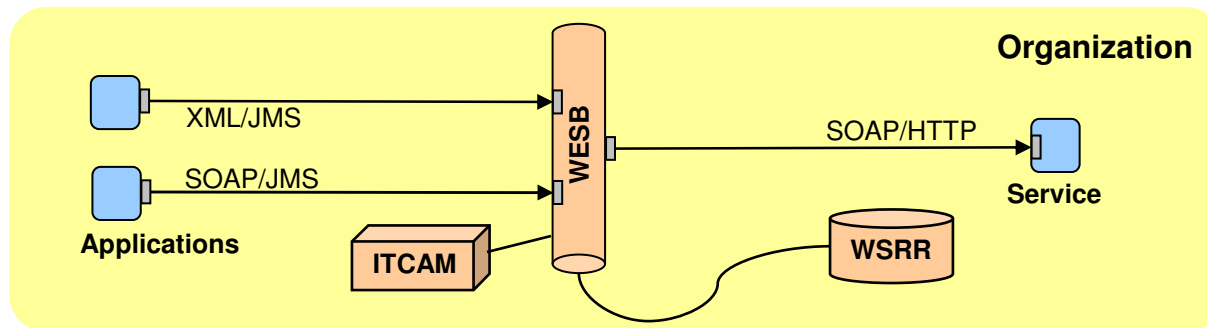

- Goals

- Applications need to access a service with different interface/protocol
 - Mediation desired to 'standardize' service requests while leaving applications unchanged
- Flexible Control of service access
- Management and monitoring of environment

- Solution

- WebSphere ESB 6.0.2 matches skill set and cost targets
- ITCAM for SOA 6.1 monitors runtime environment
- WSRR 6.0.2 enables dynamic metadata-driven routing global to enterprise

Multi-Channel Access

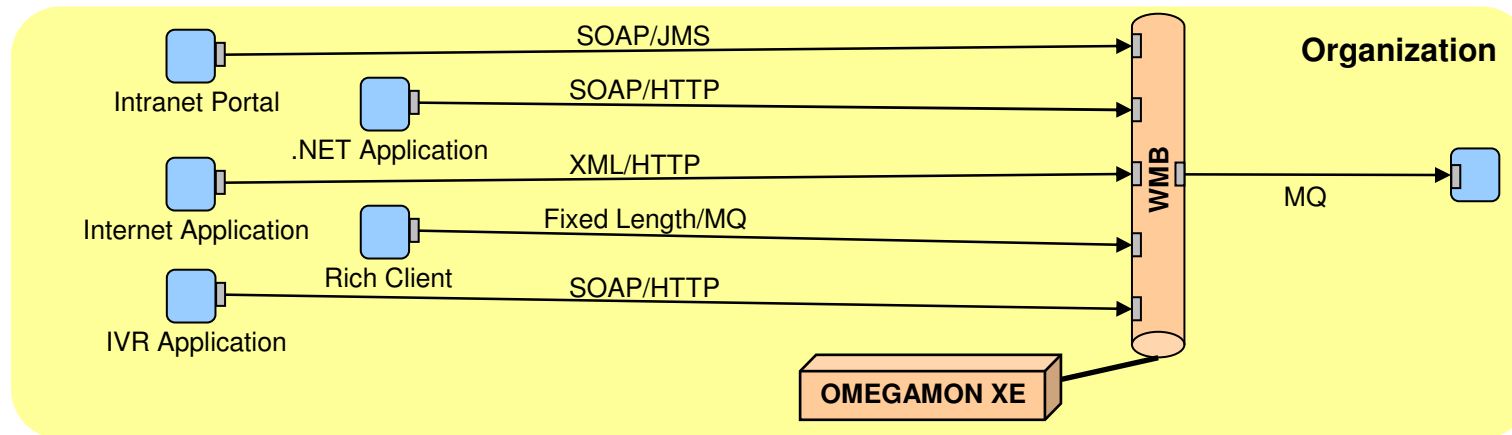

- Goals
 - Common service(s) for heterogeneous channels
 - High capacity and flexibility
 - Management and monitoring of Solution
- Solution
 - WebSphere Message Broker 6.0 matches skill set and capacity targets
 - OMEGAMON XE monitors runtime environment

Adapting enterprise applications

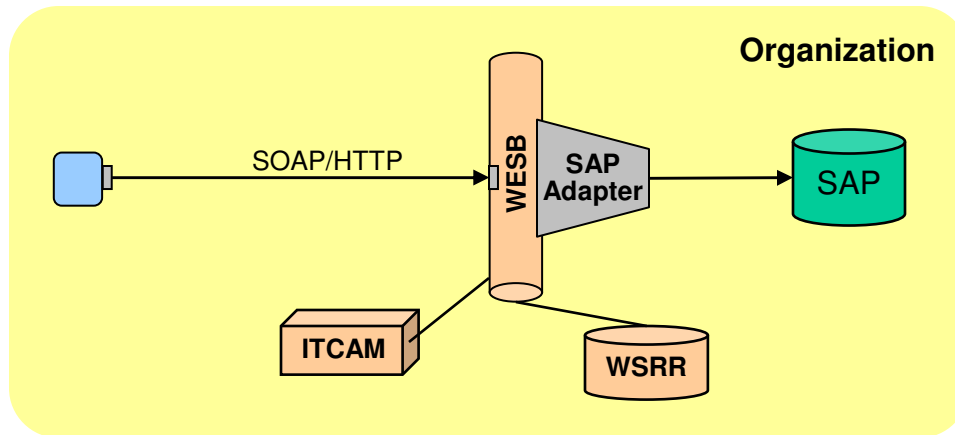

- Goals

- Desire flexible web service access to SAP R/3 and other EIS systems.
 - Moderate volume of requests
- Management and monitoring of Solution

- Solution

- WebSphere ESB 6.0.2 matches skill set and cost targets
 - SAP JCA adapter available with WESB
- ITCAM for SOA 6.1 monitors runtime environment
- WSRR 6.0.2 enables dynamic metadata-driven routing global to enterprise

Business value driven availability

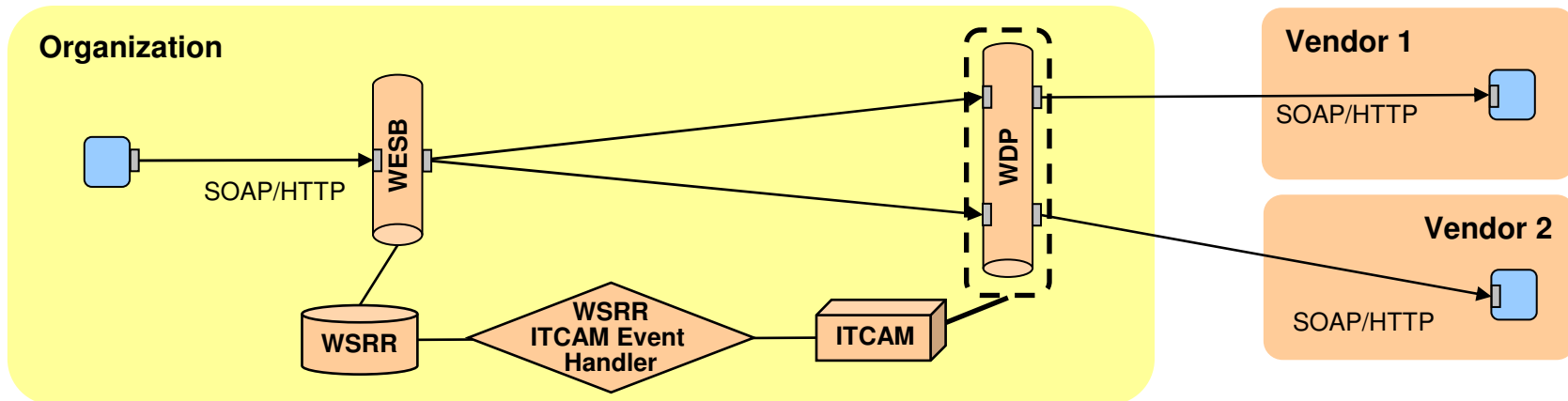

- Goals

- Engage different business partners to serve different constituencies
 - First cheap, but with variable and sometimes unacceptable response times
 - Second more expensive, but with significantly better and less variable response time
- Secure interactions with external business partners
- Flexible Control of service access
 - Access based on availability and cost
- Monitoring of business partner response

- Solution

- WebSphere ESB 6.0.2 matches skill set and cost targets
- WebSphere DataPower XS40 or XI50 for Service Proxy, XML firewall and Web Services Security
- ITCAM for SOA 6.1 monitors vendor response time via WDP
- WSRR 6.0.2 enables dynamic metadata-driven routing
- WSRR ITCAM for SOA Event Handler SA04 reflects ITCAM metrics in WSRR meta-data

ESB driven by Meta-data and Policies

ESB use of Service Metadata

- Support in
 - WebSphere Message Broker
 - WebSphere Enterprise Service Bus
 - WebSphere DataPower

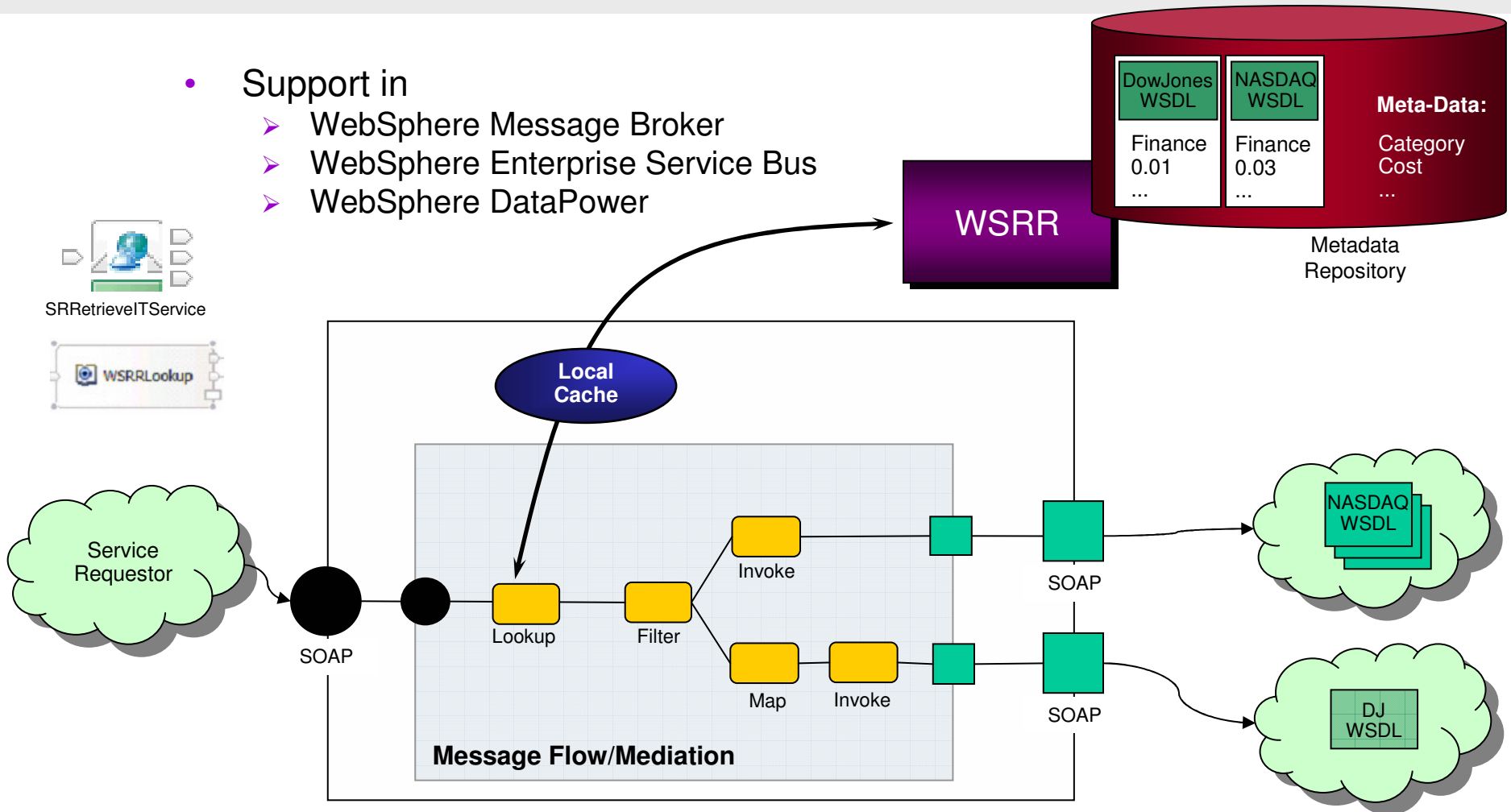

Adding Service Status Awareness Metadata

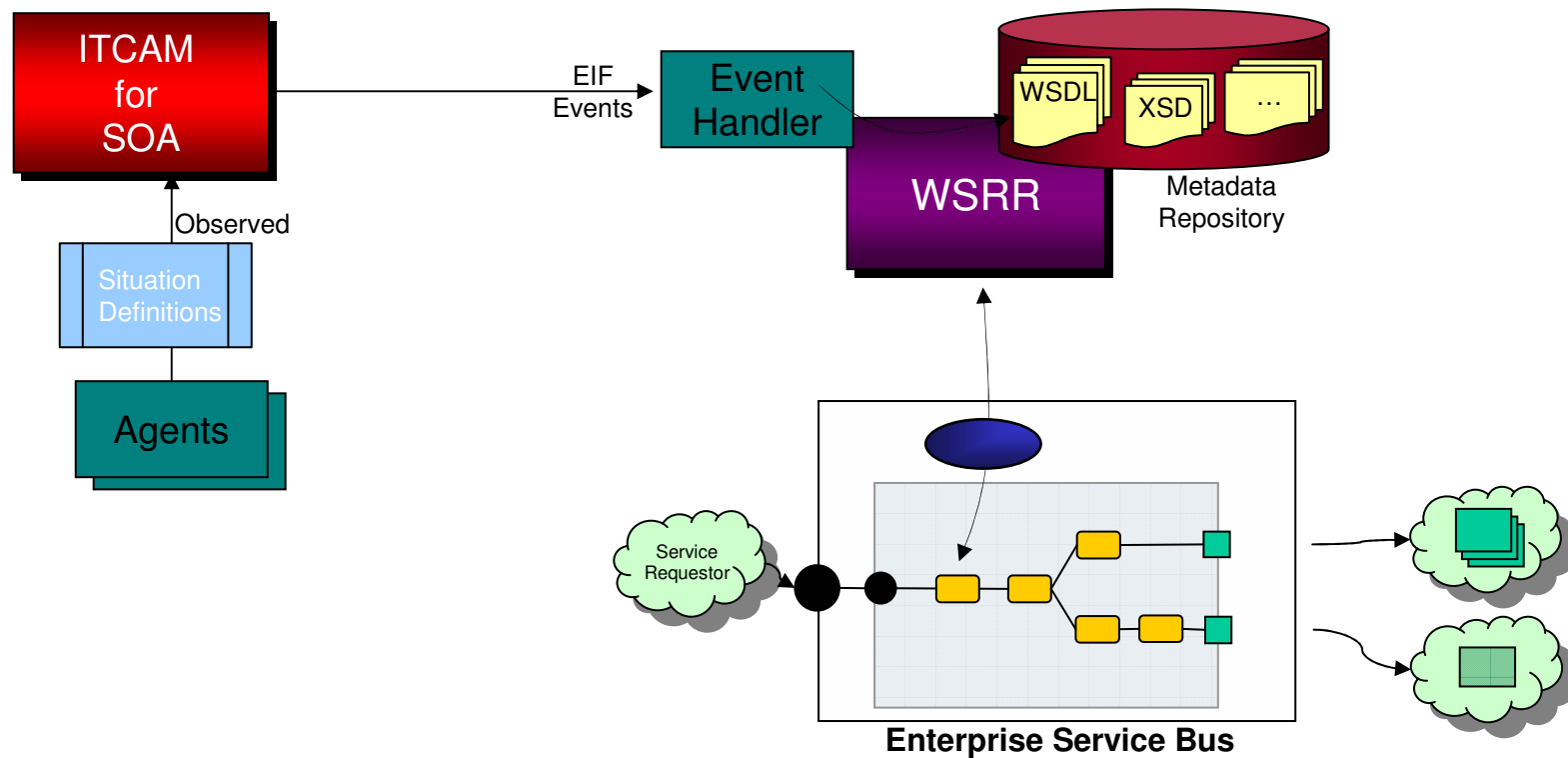

Policy Based Interaction Management

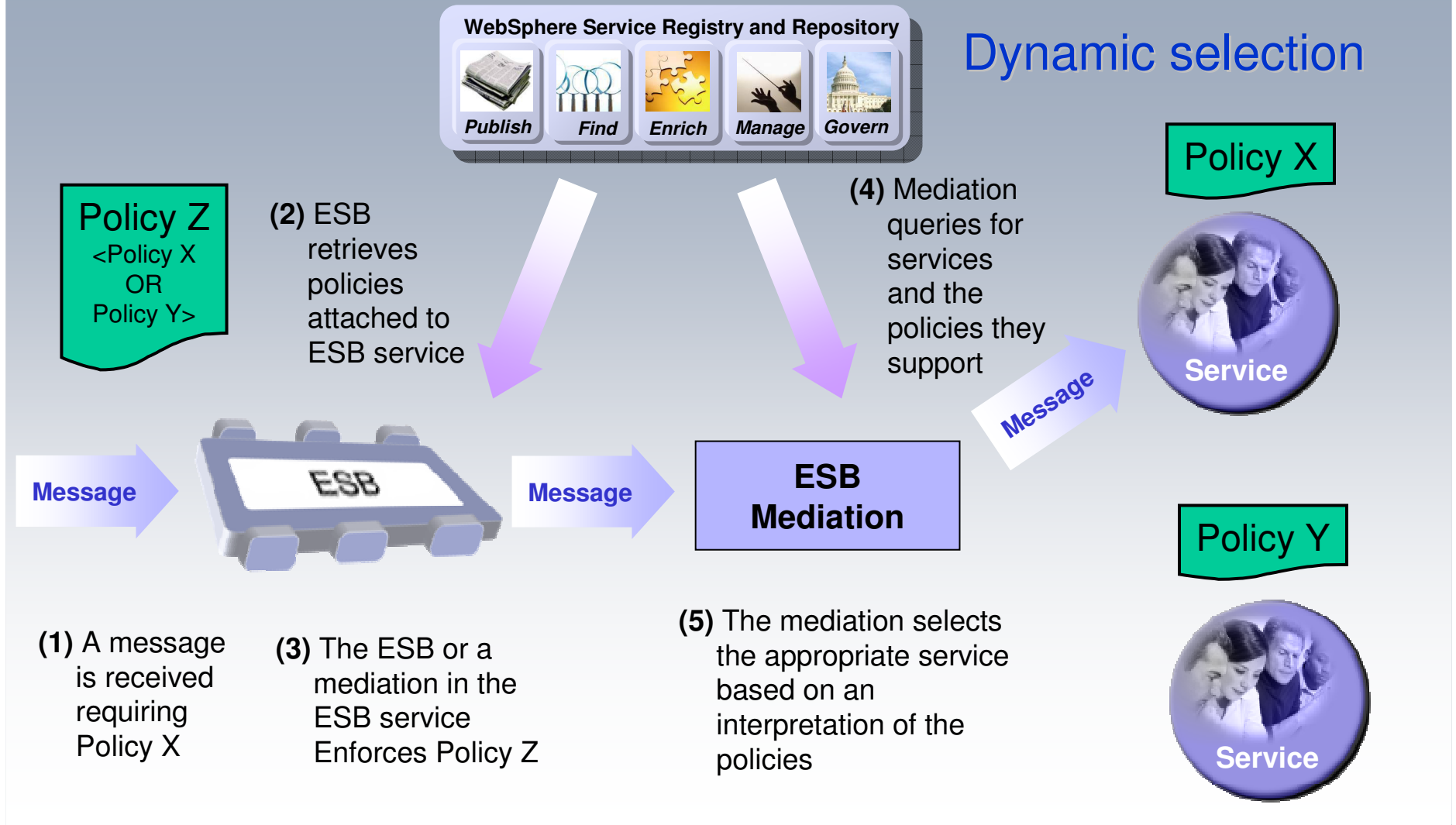

Summary

- Define your ESB architecture and terminology
 - ESB components and related components
 - Specifically look at adapters, universal transformation, security enforcement, monitoring, and registry
- Define and prioritize your functional and non-functional requirements
- Evaluate ESB products using your prioritized requirements
- Develop and deliver ESB function incrementally

Do you have any

QUESTIONS ?

IBM Tivoli Composite Application Manager

1. Service Discovery & Reconciliation

- ITCAM for SOA discovers “*rogue services*” running in production by comparing with registered services in WSRR

2. Service Monitoring & Logging

- ITCAM for SOA maintains logs of service calls in data warehouse (for historical reporting)
- Monitors for service degradation and thresholds defined by service level agreements
- Automated ‘take action’ commands to re-route services to meet SLAs

3. Views Optimized for Operations and Web Services SMEs

- Tivoli Usage & Accounting manager creates reports for chargeback
- Tivoli Service Level Advisor creates SLA reports for compliance

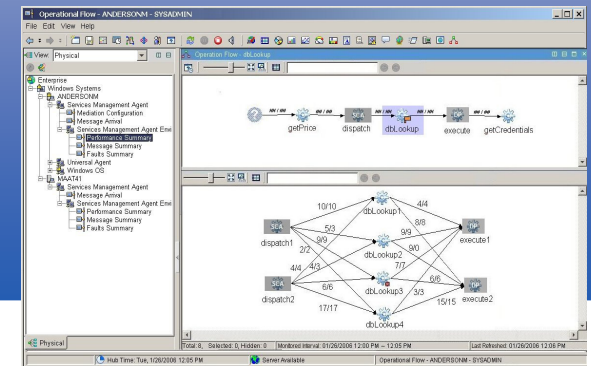
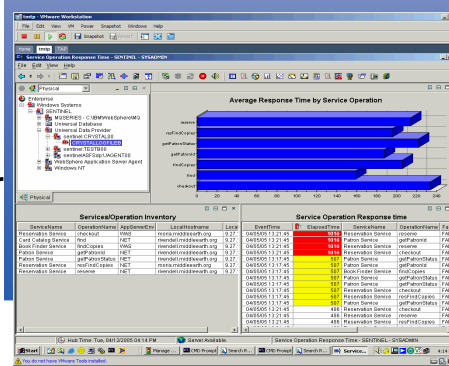
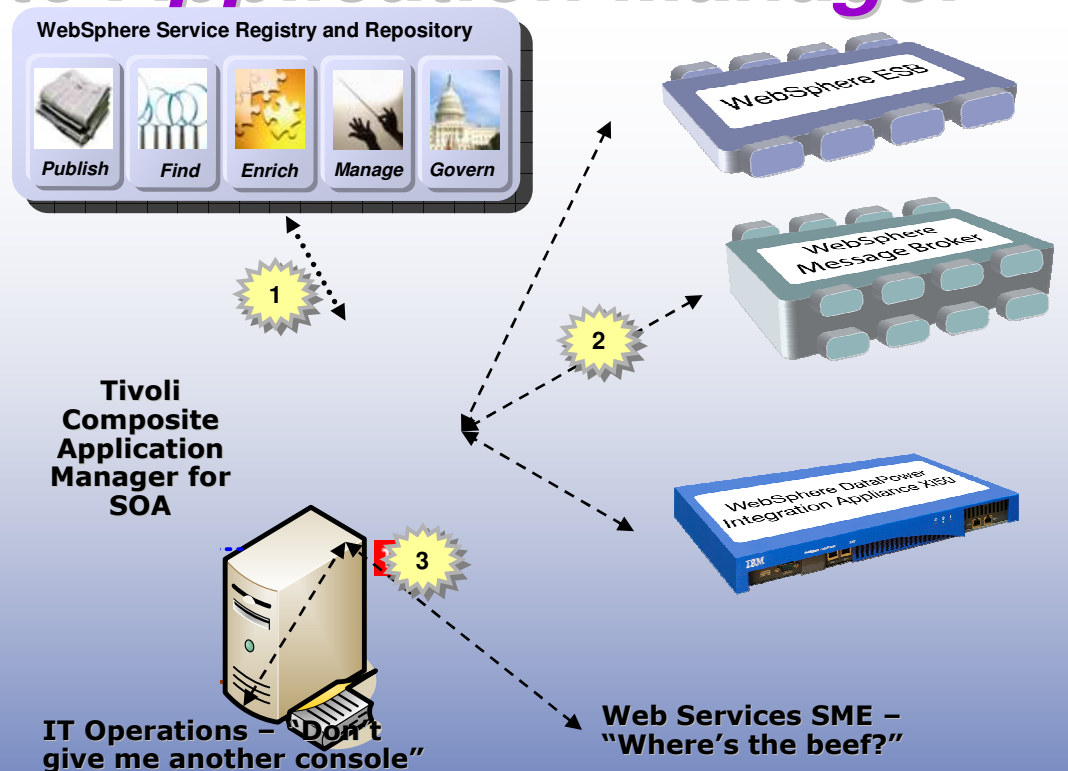

Tivoli Federated Identity Management

- Provides identity and access control services that enable architects and developers to migrate identity processing out from applications into reusable services
 - Provides standards-based, end-to-end identity translation and access control from point of contact (e.g. XML firewall) –to– mainframe (e.g. CICS)
 - Includes Tivoli Access Manager
- TFIM makes an Enterprise Service Bus “*identity aware*”
 - WebSphere Enterprise Service Bus
 - WebSphere Message Broker
 - WebSphere DataPower Integration Appliance XI50
 -Other ESBs (via open standards)

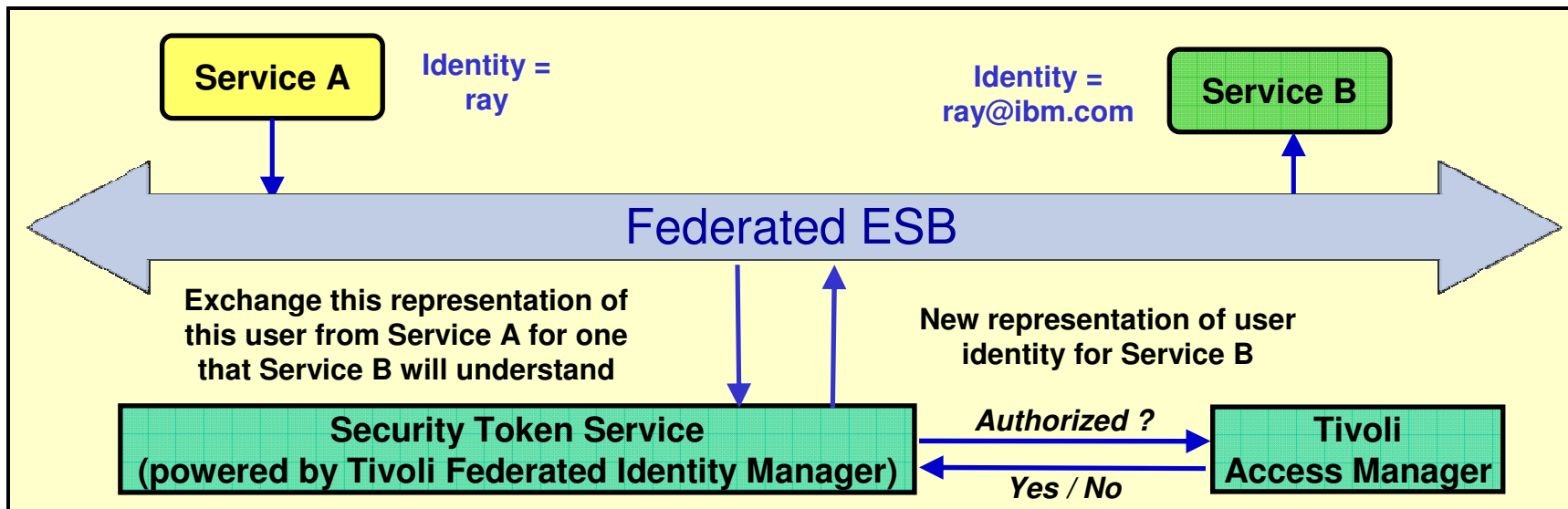

WebSphere Service Registry and Repository 6.1

- Provides usability and consumability enhancements
 - Graphical views of service metadata
 - Faceted type-ahead search to progressively refine results
 - Editors to drive all operations
 - Service Discovery from WebSphere and .Net platforms for service reuse and governance
 - Simplifies installation and configuration with support for Derby database
- Enhances federation of service information
 - Shares consistent service information and service models with WebSphere Business Services Fabric
- Promotes SOA principles for WebSphere MQ applications with new service representation
 - Metamodel and extensible parser supporting service representation of WebSphere MQ endpoints
- Enhances service governance and lifecycle management
 - New promotion model
- Leverages ongoing Early Access Program driving collaborative development approach with customers

The Federated ESB at a glance

- Service Registry: **WebSphere Services Registry and Repository**
 - Store, access, and manage information to support a successful service-oriented architecture (SOA) implementation
- Service Management: **ITCAM for SOA**
 - Service management solution to monitor and log service performance
- Service Security
 - **Tivoli Federated Identity Manager**
 - User access management solution to provide federated SSO and deliver a centralized, pluggable identity trust management service
 - **Tivoli Access Manager**
 - User access management solution to provide web SSO and protect diverse set of web applications & resources
 - **WebSphere DataPower XML Security Gateway XS40**
 - XML threat protection and security enforcement
 - **Tivoli Identity Manager**
 - User management solution to provision & manage user identities throughout their lifecycle.

